

Saflec Systems (Pty) Ltd

SSR-250-D Display proximity reader

Revision 1.0 - (June 27, 2007)

Quick Start Guide

Introduction

The SSR-250-D is a display board with a 16 character by 2 line LCD display that connects to an internally mounted proximity reader board.

The SSR-250-D connects to the controllers using an RS-485 network.

The proximity reader can read various transponder cards at the industry standard frequency of 125 kHz, including Hitag™ 1, Hitag™ 2 and HT4102.

It includes a tri-color LED for indication of the scanner status, and a Piezo buzzer to indicate a successful card read.

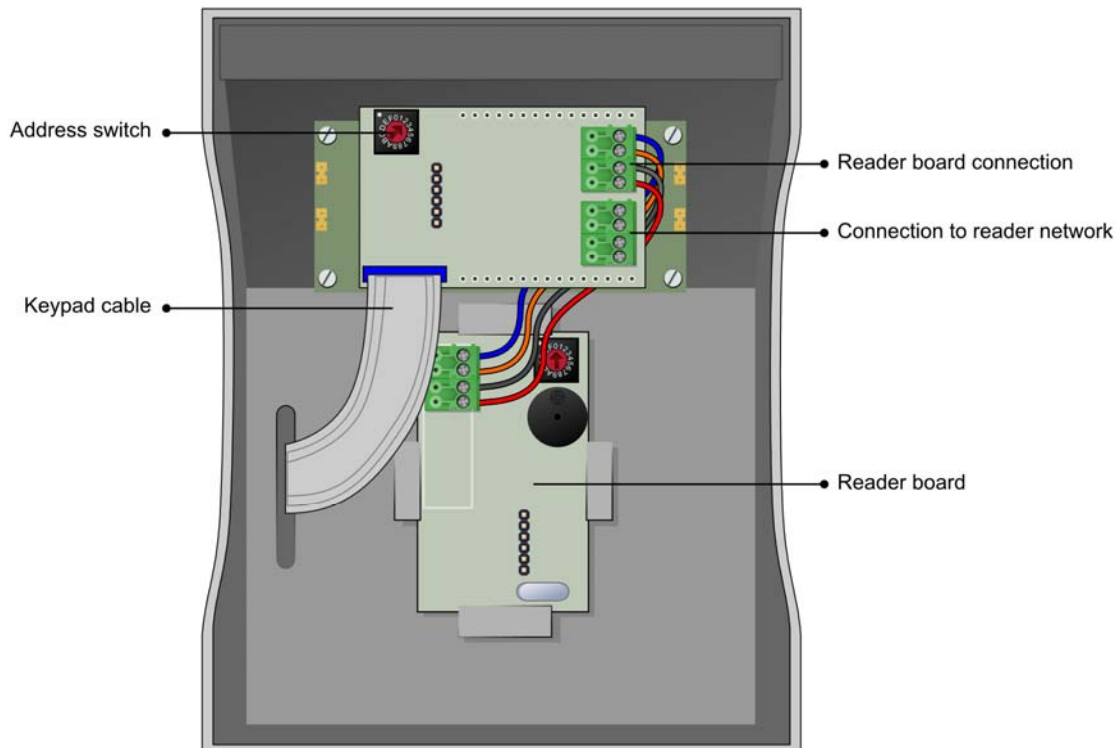

Figure 1
SSR-250-D display proximity reader with feature labels

Step 1: Set the address using the address switch**Setup instructions****Step 1: Set the address using the address switch** (See Fig 1)

The SSR-250-D communicates with the master controller via a multi-drop RS-485 communications network. Each device on this network requires a unique address for communications and identification. Duplicate addresses will cause communication problems.

The address of this reader can be a number from 0 to F. This setting can be adjusted using the rotary dipswitch on the display board. Turn the dial until the arrow points to the address that you wish to assign to the display.

**Figure 2**

Address switch with address 1 selected

Note: This address will be the same address as used in the SACS software where A = 10 and F = 15.

Note: The address switch on the reader board should be set to 0 as it is a slave device to the display board.

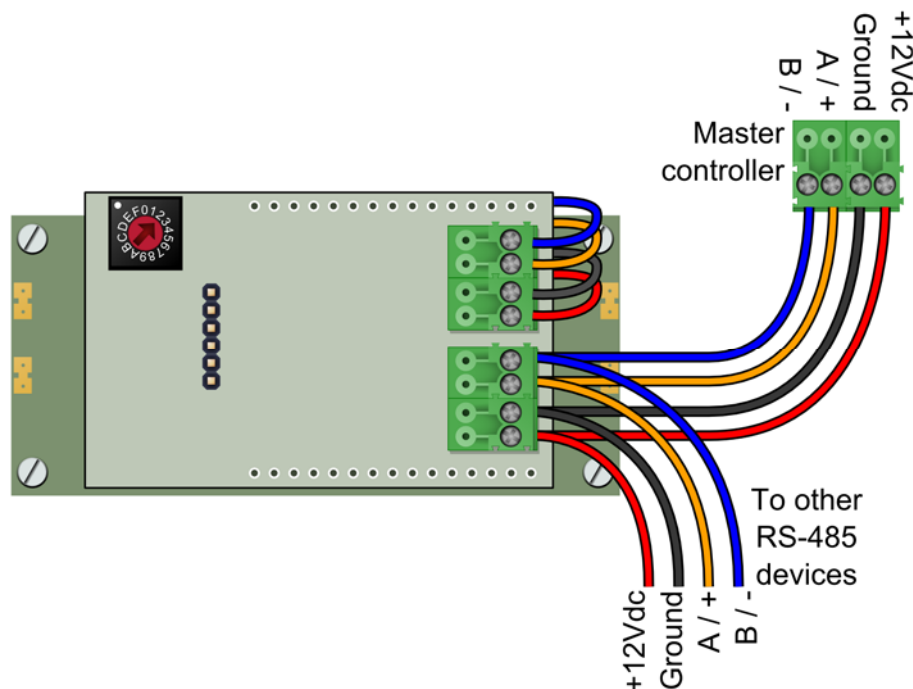
**Figure 3**

SSR-250-D connections to the controller and power.

Step 2: Connect the reader network (See Fig 3)

Connect the RS-485 network to the SSC-001 controller card and to any other readers or compatible devices (eg. SSR-201 / SSE-720 / SSI-300-W) on the line.

Each device in the network will have a positive (A) and a negative (B) connector which connect to the corresponding line on the reader network. RS-485 connections are always made this way, so all RS-485 devices on the line will be wired in the same way.

Step 3: Connect the power (See Fig 3)

Connect the reader to the power supply. In figure 3 the power is being drawn from the controller, however this is not necessary. You could have a separate power supply for the device, however it's recommended that the ground wire is still wired up with the signal cable as well as the power source.

Note: The power supply must be a 12 Volt DC power supply, capable of supplying 250mA. The reader can be powered from the master controller if the supply can deliver sufficient power.

When power is supplied to the reader the Piezo buzzer will sound and the LED will begin flashing blue. The display will flash 'Check host comms' until the controller connects. As soon as the date and time has been received from the controller it will start showing the date and time.

Product specifications

Power requirements

Operating Voltage (DC)	10 to 14 Vdc
Maximum Current	250 mA

Environmental characteristics

Operating Temperature	0°C to +70°C
Storage Temperature	-10°C to +80°C